

STANDARDIZED TEST METHODS

AMBULANCE
MANUFACTURERS
DIVISION



A division of
NTEA
THE ASSOCIATION FOR THE WORK TRUCK INDUSTRY

AMD Standardized Test Methods – 2019

Except where definitions are included in the individual Standardized Test Method, terms shall have the meaning ascribed to them in the applicable standard (e.g., Federal Specification for the Star-of-Life Ambulance, NFPA 1917 Standard for Automotive Ambulances, CAAS Ground Vehicle Standard for Ambulances, etc.).

When cited in a governing ambulance standard, these test methods provide a means to test to the performance levels/values specified by such standard. Where such standard does not specify a performance level/value, the levels/values in these test methods shall apply. Where a different performance level/value is specified by such standard, the level/value in the governing standard shall apply.

LEGAL NOTICE AND DISCLAIMER

AMD STANDARDIZED TEST METHODS ARE PROVIDED AS AN INFORMATIONAL RESOURCE ONLY AND ARE NOT INTENDED TO, AND SHOULD NOT, BE USED AS A SUBSTITUTE FOR A COMPANY'S INDEPENDENT ENGINEERING, SAFETY AND LEGAL ANALYSIS AND JUDGMENT. NTEA MAKES NO REPRESENTATIONS OR WARRANTIES CONCERNING THESE TEST METHODS, INCLUDING WITHOUT LIMITATION, THAT THESE TEST METHODS ARE COMPLETE OR ERROR-FREE. NTEA UNDERTAKES NO OBLIGATION TO UPDATE THESE TEST METHODS IN ANY MANNER. NTEA RESERVES ALL INTELLECTUAL PROPERTY RIGHTS IN OR RELATED TO AMD STANDARDIZED TEST METHODS.

Introduction

Emergency medical services in the U.S. is represented by Ambulance Manufacturers Division (AMD), a division of NTEA – The Association for the Work Truck Industry¹. NTEA is the only trade association representing the nation's manufacturers and distributors of commercial trucks, truck bodies, truck equipment and accessories².

AMD is dedicated to the production of safe, state-of-the-art ambulances. Currently composed of approximately 60 member companies, AMD has consistently maintained representation of the majority of ambulance production in North America. Since its founding in 1976, AMD has worked closely with all state and federal regulatory agencies and has been directly involved in activities that benefit the general public as well as the industry. These activities include:

- Partnership with National Institute of Occupational Safety and Health, other federal agencies and SAE International to research and develop new, dynamic test methods to evaluate and improve occupant safety of the patient compartment.
- Partnership with General Services Administration (GSA) in further development and revision of KKK-A-1822.
- Active involvement with truck chassis manufacturers in the development of new models and options that make chassis more compatible for ambulance service.
- Support of OEM quality programs, including the Ford Qualified Vehicle Modifier (QVM) Program, Ram Quality Professional (Q-Pro) and the MasterUpfitter Program of Daimler Vans USA LLC.
- Continued development, improvement and updating of AMD Standardized Test Methods and other industry standards.

Development of AMD Standardized Test Methods began decades ago by AMD members, in conjunction with GSA. These Standardized Test Methods are currently cited by (1) Federal Specification for the Star-of-Life Ambulance (KKK-A-1822), (2) National Fire Protection Association 1917 Standard for Automotive Ambulances (NFPA 1917) and (3) Commission on Accreditation of Ambulance Services/Ground Vehicle Standard for Ambulances (CAAS/GVS). To the extent cited in a standard of KKK-A-1822, NFPA 1917 or the CAAS/GVS, the applicable AMD Standardized Test Method is intended to provide a verifiable means to test the relevant performance requirements in that standard.

Federal laws and regulations require that motor vehicles, including ambulances, comply with all applicable Federal Motor Vehicle Safety Standards (FMVSSs). The National Highway Traffic Safety Administration (NHTSA) of the U.S. Department of Transportation oversees these FMVSSs. All AMD Standardized Test Methods are in addition to, and in no way a substitute for, FMVSSs and other federal or state requirements that apply to motor vehicles and other regulated aspects of ambulances and their intended functions.

From time to time, AMD Standardized Test Methods are revised. Please note a relevant standard/specification (e.g., an NFPA 1917 standard) may refer to an older version of AMD Standardized Test Methods. In such a case, compliance with such standard/specification may require use of the older Standardized Test Methods.

¹ Prior to 1986, AMD was a division of Truck Body and Equipment Association.

² NTEA members include companies that produce highly specialized vehicles, such as ambulances, towing and recovery vehicles, small school buses and mid-size buses. The Association provides its 2,100+ member companies with in-depth technical information, education, and member programs and services. Headquartered in suburban Detroit, Michigan, NTEA also interacts directly with major truck chassis manufacturers on product compatibility issues. In addition, through its government relations offices in Washington, DC, and Ottawa, Ontario, NTEA provides members with information on regulations affecting commercial trucks, and lobbies on the industry's behalf.



STANDARDIZED TEST METHODS

Contents

AMD 001	 Reserved (refer to SAE J3057)	
AMD 002	 Reserved (refer to CFR 49 Part 571.206)	
AMD 003	 Reserved (refer to SAE J3043 and AMD 028 - 2019)	
AMD 004	 Litter Retention System Static Test - 2019	4
AMD 005	 Low Voltage Electrical System Test - 2019	5-6
AMD 006	 Patient Compartment Sound Level Test - 2019	7
AMD 007	 Patient Compartment Carbon Monoxide Level Test - 2019	8
AMD 008	 Patient Compartment Handrail Static Load Test - 2019	9
AMD 009	 125V AC Electrical Systems Test - 2019	10
AMD 010	 Water Leak Test - 2019	11
AMD 011	 Equipment Temperature Test - 2019	12
AMD 012	 Interior Climate Control Test - 2019	13-14
AMD 013	 Weight Distribution Measurements - 2019	15-16
AMD 014	 Engine Cooling System Test - 2019	17
AMD 015	 Ambulance Main Medical Gas System Test - 2019	18
AMD 016	 Patient Compartment Lighting Level Test - 2019	19
AMD 017	 Road Test - 2019	20
AMD 018	 Rear Stepping Surface Load Test - 2019	21
AMD 019	 Cabinet & Compartment Measurements - 2019	22-23
AMD 020	 Floor Distributed Load Test - 2019	24-25
AMD 021	 Aspirator System Test - 2019	26
AMD 022	 Cold Engine Start Test - 2019	27-28
AMD 023	 Siren Performance Test - 2019 rev. 1	29
AMD 024	 Perimeter Illumination Test - 2019	30-31
AMD 025	 Occupant Head Clearance Zones Test - 2019	32
AMD 026	 Ambulance Emergency Lighting System Configuration - 2019	33-35
AMD 027	 Line Voltage Electrical Systems Test - 2019	36-38
AMD 028	 Vertical Component Retention — Static Test - 2019	39-40
Annex		41-43



STANDARDIZED TEST METHODS

AMD 004 | Litter Retention System Static Test – 2019

S1. SCOPE AND PURPOSE.

This standard establishes minimum requirements for testing the installation of the litter retention system when installed per the manufacturer's directions. This is a type test.

S2. APPLICABILITY.

This standard applies to all ambulances.

S3. DEFINITIONS.

S3.1 "Litter retention system" means a system that provides means for securing a litter by the posts and wheels to the floor and/or side wall of an ambulance.

S3.2 "Litter" means a wheeled cot (elevating) and/or a wheeled cot-bench (non-elevating).

S4. REQUIREMENTS.

Each litter retention system shall be capable of meeting requirements set forth under this standard when tested in accordance with test procedures outlined in S6.

S4.1 The litter retention system, anchorages and litter fastener(s) shall not fail or release when subjected to the cot manufacturers recommended load or a minimum force of 2,200 lbs. applied in the longitudinal, lateral and vertical direction. (Note: These are three individual tests.)

S5. TEST CONDITIONS.

The following conditions apply.

S5.1 The ambulance floor shall be in a horizontal plane.

S5.2 If multiple locations exist, the litter retention system shall be tested in each location.

S5.3 The testing device is a structure of appropriate design used for locking onto the hook(s) (or other litter securing means) of the litter retention system (similar to the cot frame). Force is applied through a pivot located 15" above the floor at a point representing the center of the litter.

S6. TEST PROCEDURES.

S6.1 Install the test device in the litter retention system in such a manner that will preclude contact friction with the floor or cabinet surfaces.

S6.2 Attach a calibrated, in-line strain gauge to the test device pivot and apply an initial vertical upward load to the device.

S6.3 As rapidly as possible, apply the full force required in S4.1 to the device.

S6.4 Record strain gauge readings and observe any deformation of floor, cabinets or retention mechanism.

S6.5 Release applied load.

S6.6 If any deformation has occurred in the retention mechanism (i.e., hooks, antlers or side bars) replace damaged parts.

S6.7 Reinstall test fixture and repeat steps S6.1 through S6.5 in the longitudinal direction and again in the lateral direction.

S6.8 Record all resultant data.

Note: Rotation or deformation of retention mechanisms does not constitute failure.



STANDARDIZED TEST METHODS

AMD 005 | Low Voltage Electrical System Test – 2019

S1. SCOPE.

This standard establishes testing and certification requirements for ambulance electrical systems.

S2. PURPOSE.

The purpose of this standard is to verify performance of an ambulance 12-volt DC electrical system. Each finished vehicle shall be tested.

S3. DEFINITION.

S3.1 “Common point” means a point in the ambulance 12-volt DC electrical system that is common for the electrical generating and storage system to the electrical consuming system of the vehicle, at which the current is to be measured.

S4. TEST PROCEDURE.

S4.1 The ambulance’s low voltage electrical system shall be tested as required by this section, the test results shall be certified by the ambulance manufacturer, and the certified test results shall be delivered with the ambulance.

S4.2 Tests shall be performed when the ambient air temperature is between 60°F and 110°F (15°C and 43°C).

S4.3 Before each test, the batteries shall be fully charged until the voltage stabilizes at the voltage regulator set point and the lowest charge current is maintained for 10 minutes.

S4.3.1 Failure of any of these tests shall require a repeat of the sequence.

S4.3.2 Reserve Capacity Test.

S4.3.2.1 The engine shall be started and kept running until the engine and engine compartment temperatures are stabilized at normal operating temperatures and the battery system is fully charged.

S4.3.2.2 The engine shall be shut off, and the minimum continuous electrical load, as stated in the governing standard, shall be activated for 10 minutes.

S4.3.2.3 All electrical loads shall be turned off prior to attempting to restart the engine.

S4.3.2.4 The battery system shall then be capable of restarting the engine.

S4.3.2.5 Failure to restart the engine shall be considered a test failure of the battery system.

S4.3.3 Alternator Performance Test at Idle.

S4.3.3.1 The minimum electrical load test conditions as stated in the governing standard shall be activated with the engine running at idle speed.

S4.3.3.2 The engine temperature shall be stabilized at normal operating temperature.

S4.3.3.3 The battery system shall be tested to detect the presence of battery discharge current.

S4.3.3.4 The detection of battery discharge current shall be considered a test failure.

S4.3.4 Alternator Performance Test at High Idle.

S4.3.4.1 The operational electrical load test conditions as stated in the governing standard shall be activated with the engine running at high idle.

S4.3.4.2 The test duration shall be a minimum of 30 minutes with engine at operating temperature.

S4.3.4.3 Engine speed shall not exceed 1600 RPM

S4.3.4.4 Activation of the load management system shall be permitted during this test.



STANDARDIZED TEST METHODS

- S4.3.4.5** An alarm sounded by excessive battery discharge, as detected by the warning system, or a system voltage of less than 11.8 volts DC for a 12-volt nominal system, 23.6 volts DC for a 24-volt nominal system, or 35.4 volts DC for a 42-volt nominal system for more than 120 seconds shall be considered a test failure.
- S4.4** Low Voltage Alarm Test.
- S4.4.1** The following test shall be started with the engine off and the battery voltage at or above 12 volts for a 12-volt nominal system, 24 volts for a 24-volt nominal system, or 36 volts for a 42-volt nominal system.
- S4.4.2** With the engine shut off, the total continuous electrical load shall be activated and shall continue to be applied until the excessive battery discharge alarm activates.
- S4.4.3** The battery voltage shall be measured at the battery terminals.
- S4.4.4** The test shall be considered a failure if the alarm does not sound in less than 140 seconds after the voltage drops to 11.70 volts for a 12-volt nominal system, 23.4 volts DC for a 24-volt nominal system, or 35.1 volts for a 42-volt nominal system.
- S4.4.5** The battery system shall then be able to restart the engine.
- S4.4.6** Failure to restart the engine shall be considered a test failure.



AMD 006 | Patient Compartment Sound Level Test – 2019

S1. PURPOSE AND SCOPE.

This standard establishes the requirements for measuring the maximum sound level for ambulance patient compartments. This is a type test.

S2. APPLICABILITY.

This standard applies to all ambulances.

S3. REQUIREMENTS.

The interior sound level in the patient compartment shall not exceed 80 decibels.

S4. TEST PROCEDURE.

S4.1 This test shall be performed during the following environmental conditions:

1. Temperature not to exceed 95°F (35°C)
2. Humidity not to exceed 75 percent relative humidity
3. Wind velocity not to exceed 12 mph (19 km/hr)
4. Barometric pressure 29 in. Hg to 31 in. Hg (98.2 kPa to 104.9 kPa)

S4.2 The following steps shall be performed during the patient compartment sound level test:

1. Measure sound level using a meter that meets the requirements of ANSI S1.4, Specification for Sound Level Meters, for Type II meters with the meter set to A for a weighting network, “fast” meter response.
2. Suspend the microphone 23 in. (584 mm) above the vehicle floor, centered laterally and longitudinally on the expected center of the patient cot as it will be secured in the patient compartment.
3. Park the ambulance on a concrete or asphalt surface, at a location so that no large reflecting surfaces, such as other vehicles, signboards, buildings, or hills, are within 50 ft (15.2 m) of the vehicle being tested.
4. Close all ambulance doors, windows, and vents.
5. Run air conditioner and heater blower fans in patient compartment at the highest speed.
6. Set vehicle transmission in neutral gear and set the engine speed to the rpm obtained by the ambulance when operating on level ground at 55 mph (88 km/hr).
7. Turn on all warning lights.
8. Operate siren in the loudest mode.
9. Measure and record the highest sound level.
10. Decrease the engine speed to idle and then back to the 55 mph (88 km/hr) rpm.
11. Measure and record the highest sound level.
12. Repeat until two maximum sound levels within 2 decibels (dB) of each other are recorded.
13. Numerically average these two maximum sound level readings.



STANDARDIZED TEST METHODS

AMD 007 | Patient Compartment Carbon Monoxide Level Test – 2019

S1. PURPOSE AND SCOPE.

This standard establishes the minimum requirements for testing for the presence of carbon monoxide (CO) gas in ambulances. This is a type test.

S2. TEST CONDITIONS.

- a. Open vehicle doors and ventilate with fresh air for 10 minutes.
- b. Do not conduct testing during high wind periods (above 15 mph) or during any type of precipitation.
- c. Calibrate equipment at start of test.

S3. TEST EQUIPMENT.

- a. CO meter capable of calibration to 10 parts per million (ppm).
- b. Canister of 10 ppm CO.

S4. TEST PROCEDURE.

Using a CO meter calibrated to 10 ppm, perform the following:

S4.1 Sample ambient air around the outside of the vehicle and record.

S4.2 Close all doors and windows of vehicle, assuring that heating, air conditioning and ventilating systems are off.

S4.3 Start and idle engine in parked position for 10 minutes.

S4.4 Monitor CO at head of primary cot for the first five minutes and record results.

S4.5 Monitor CO around doors, windows and floor for the remaining five minutes and record results.

S4.6 With environmental systems remaining off, drive the vehicle for 10 minutes on traffic laden city streets (15–30 mph).
Exception: windshield defrost may be run to operate the vehicle in a safe manner.

S4.7 Repeat S4.4.

S4.8 Repeat S4.5.

S4.9 With environmental systems remaining off, drive vehicle for 10 minutes on limited access (interstate) highway (45–65 mph).
Exception: windshield defrost may be run to operate the vehicle in a safe manner.

S4.10 Repeat S4.4

S4.11 Repeat S4.5

S4.12 Stop vehicle and repeat S4.1

S5. CALCULATION OF RESULTS.

S5.1 Determine the average reading taken in S4.1 and S4.2.

S5.2 Deduct result of S4.1 from the highest reading taken in each of the three tests. The resultant levels of CO shall not exceed 10 ppm.

S5.3 Record all results noting time, date, location and route of tests. Record temperature, barometric pressure and humidity at the time of the test



AMD 008 | Patient Compartment Handrail Static Load Test – 2019

S1. PURPOSE AND SCOPE.

This standard establishes minimum requirements for testing an ambulance grab rail. This is a type test.

S2. APPLICABILITY.

This standard applies to all ambulances.

S3. REQUIREMENTS.

Handrails shall withstand a force of 300 lbs. (136 kg) applied in the directions specified in S4 without detaching.

S4. TEST PROCEDURE.

The following steps shall be performed during the handrail static load test.

1. Apply force to handrail at the midpoint between every location where the handrail fastens to the vehicle body structure and as near as possible to the ends of the handrail, as shown in Figure 1.
2. Apply the force perpendicular to the mounting surface.
3. Apply the force parallel to the mounting surface.
4. Apply the force diagonal to the mounting surface at an angle midway between the perpendicular and the parallel pulls, as shown in Figure 2.
5. Maintain each force application for 2 minutes.

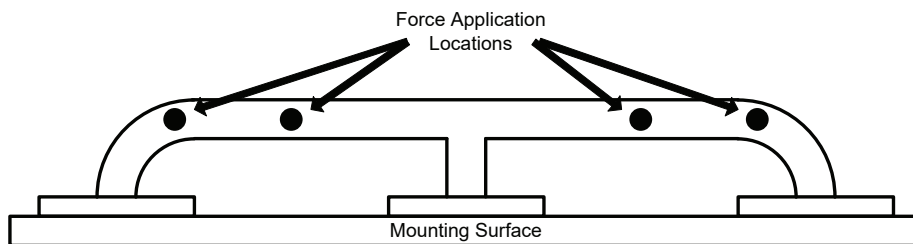

Figure 1 | Location of Force Application on Handrail

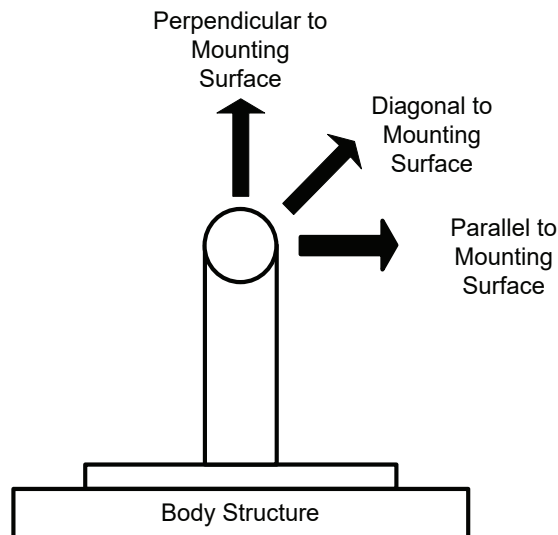

Figure 2 | Direction of Force Application on Handrail



STANDARDIZED TEST METHODS

AMD 009 | 125V AC Electrical Systems Test – 2019

S1. SCOPE AND PURPOSE.

This standard establishes test requirements for ambulances and equipment installed within or on ambulances and the conductors that connect ambulances to 125-volt, nominal, AC electrical supply system(s).

S2. APPLICABILITY.

This standard applies to all ambulances.

S3. DEFINITIONS.

S3.1 “Dielectric Test (withstanding)”, a test of the insulation between normal current carrying conductors (hot and neutral) and the ground (ambulance shoreline ground or ambulance chassis ground). This is accomplished by applying higher than normal voltage across the insulation for a given period of time. The purpose of this test is to detect any ‘weak spots’ in the insulation of the “current carrying conductor/s.

S3.2 “Continuity Test” means the testing to ensure all metallic parts that may become energized are properly bonded and that the bonding path is complete.

S3.3 “Operational Test” means testing all added 125-volt equipment or outlets for function.

S3.4 “Polarity Test” means using a polarity or circuit tester with built-in GFCI tester to test all outlets for proper polarity and GFCI protection.

S4. REQUIREMENTS.

Each ambulance shall be tested this is not a type test.

S4.1 FACTORY ELECTRICAL TESTS.

Each ambulance shall be subjected to the following tests, and the results shall be documented:

- a. Dielectric Test (withstanding). This test is accomplished by introducing a higher voltage (AC or DC), for the specified period of time per Table 1 (or) per test parameters below, to assure the wire insulation will perform as designed and installed.

Test Voltage	Time	Trip Current
900 - 1079 volts AC	60 seconds	10 – 50 mA
1273 -1526 volts DC	≥ 2- 5 s	≥ 1 – 3 mA

Table 1 | Common Dielectric Test Parameters Used for Testing 125-Volt Circuits

The dielectric withstanding test is to be performed between ungrounded and grounded conductors of the ambulance on all 125-volt circuits.

Note 1: This test is to be conducted after all production activities that may damage conductors, such as cabinet set, trim/upholstery installation and any final assembly.

Note 2: All wiring installed by the ambulance manufacturer that supplies current from a generator or inverter to the ambulance branch circuits must be dielectric tested. Generators and inverters need to be disconnected to reduce possible test voltage damage.

Note 3: When testing 125-volt system with load transfer switch (shoreline power), the test must be performed on both sides of the switch to assure total circuit testing.

- b. Continuity Test. A continuity test is to be performed to ensure that all metallic parts are properly bonded using a volt/ohm meter or other suitable continuity tester.
- c. Polarity Test. A polarity test is to be performed using a polarity or circuit tester to ensure that all electrical connections (neutral, hot and ground) have been properly made and that all GFCI devices function as required.
- d. Operational Test. Operational tests are to be performed to demonstrate that all equipment is properly connected and in working order. This should be done through shoreline connections, inverters and generators (based on ambulance configuration/equipment) by use of volt/ohm meters, circuit tester, or by using test loads.



AMD 010 | Water Leak Test – 2019

S1. SCOPE.

This standard establishes requirements for the testing of ambulances for water leakage.

S2. PURPOSE.

The purpose of this standard is to minimize the possibility of water leakage in ambulances. Each finished vehicle shall be tested.

S3. APPLICABILITY.

This standard applies to all ambulances.

S4. REQUIREMENTS.

There shall be no water leakage into the cab, any exterior compartment, or the patient compartment.

S5. TEST PROCEDURES.

The water leak test shall be performed during the following environmental conditions.

1. Temperature above 40°F (4°C).
2. Wind velocity not to exceed 10 mph (16 km/hr).

S5.1 The following steps shall be performed during the water leak test:

1. Close all windows and doors.
2. Turn off heating, ventilating, and air conditioning (HVAC) systems.
3. Drench the entire roof, sides, front, and back of the vehicle evenly with water spray from a nozzle or combination of nozzles.
4. Continue spraying until a minimum of 40 gal (151 L) of water has been used.
5. Start engine and operate the cab and patient compartment ventilation systems at maximum ventilation rates.
6. Continue spraying until an additional minimum of 40 gal (151 L) of water has been used.
7. Inspect the interior of the cab and patient compartment for water leaks during the duration of the test.
8. At the conclusion of the test, examine all exterior lights and exterior compartments for leakage.



AMD 011 | Equipment Temperature Test – 2019

S1. PURPOSE AND SCOPE.

This standard establishes testing requirements for the ambulance and ambulance equipment over a specified ambient temperature range. This is a type test.

S2. APPLICABILITY.

This standard applies to all ambulances.

S3. REQUIREMENTS.

All interior systems, components, and permanently attached equipment shall function satisfactorily over a temperature range of 32°F to 95°F (0°C to 35°C).

S4. TEST PROCEDURES.

The following steps shall be performed during the equipment temperature test.

1. Locate the test vehicle in an environmental chamber capable of maintaining a temperature within $\pm 4^\circ\text{F}$ (2°C .)
2. Turn off all vehicle power.
3. Open all patient compartment entry doors, cabinet doors, cab door windows, and exterior compartment doors.
4. Maintain an air velocity over the vehicle of at least 5 mph (8 km/hr) throughout the entire test.
5. Cool the chamber to 32°F (0°C) and soak the vehicle at this temperature for a minimum of 3 hours.
6. Start the engine.
7. Operate all vehicle systems for 1 hour while maintaining 32°F (0°C) chamber temperature.
8. Shut off the engine.
9. Heat the chamber to 95°F (35°C) and soak the vehicle at this temperature for a minimum of 3 hours.
10. Start the engine.
11. Operate all vehicle systems for 1 hour while maintaining 95°F (35°C) chamber temperature.
12. Shut off the engine.



AMD 012 | Interior Climate Control Test – 2019

S1. SCOPE.

This standard verifies the performance of the primary heater/air conditioning system of an ambulance.

S2. PURPOSE.

The purpose of this standard is to measure and ensure adequate performance of the heater/air conditioning system in an ambulance. This is a type test.

S3. APPLICABILITY.

This standard applies to all ambulances.

S4. REQUIREMENTS.

The heating system shall be capable of raising the interior temperature from 32°F to 68°F (0°C to 20°C) within 30 minutes when tested in accordance with S5. The air-conditioning system shall be capable of lowering the interior temperature from 95°F to 78°F (35°C to 25°C) at a minimum of 40 percent relative humidity within 30 minutes when tested in accordance with S5.

S5. TEST PROCEDURES.

*The following steps shall be performed during the interior climate control test:

1. Locate the test vehicle in an environmental chamber capable of maintaining a temperature within $\pm 4^{\circ}\text{F}$ (2°C).
2. Locate three thermocouples 7 in. (178 mm) off the floor along the patient compartment centerline and equally spaced from front to back.
3. Locate three thermocouples 7 in. (178 mm) below the ceiling along the patient compartment centerline and equally spaced from front to back.
4. Locate three thermocouples midway between the floor and the ceiling along the patient compartment centerline and equally spaced from front to back.
5. Locate three thermocouples in the cab horizontally positioned 24 in. (600 mm) above the seat cushion and located 12 in. (300 mm) in front of the headrest.
6. Locate the first and third thermocouples along the centerline of the driver's and passenger's seats and center the second between the first and third.
7. Turn off all vehicle power.
8. Open all patient compartment entry doors, cabinet doors, cab door windows, and exterior compartment doors.
9. Open engine hood.
10. Maintain an air velocity over the vehicle of at least 5 mph (8 km/hr) throughout the entire test.
11. Cool the chamber to $32^{\circ}\text{F} \pm 4^{\circ}\text{F}$ ($0^{\circ}\text{C} \pm 2^{\circ}\text{C}$) and soak the vehicle at this temperature for a minimum of 3 hours.
12. Close all doors and hood with the exception of partition doors (if present) and patient compartment/cab partition window (if present).
13. Set heaters in cab and patient compartment to maximum heating setting (maximum temperature, maximum blower speed, recirculating air).
14. Record the thermocouple temperatures.
15. Shut off patient compartment dome lights.
16. Start engine and maintain transmission in neutral or park and engine high idle on with a maximum engine speed not to exceed 1600 rpm for the duration of the test.
17. Record thermocouple temperatures at 5-minute intervals up to 30 minutes.
18. Shut off the engine.
19. Open all patient compartment entry doors, cabinet doors, cab door windows, and exterior compartment doors.
20. Open the engine hood.
21. Heat the chamber to 95°F (35°C) with a minimum of 40 percent relative humidity and soak the vehicle at this temperature for a minimum of 3 hours.
22. Close the hood; all doors, with the exception of partition doors (if present); and all windows, with the exception of the patient compartment/cab partition window (if present).
23. Set the air conditioners in the cab and the patient compartment to maximum cooling setting (maximum blower speed, coldest temperature setting, recirculating air).



STANDARDIZED TEST METHODS

24. Record the thermocouple temperatures.
25. Shut off the patient compartment dome lights.
26. Start the engine and maintain the transmission in neutral or park and engine high idle on with a maximum engine speed not to exceed 1600 rpm for the duration of the test.
27. Record thermocouple temperatures at 5-minute intervals up to 30 minutes.
28. Shut off the engine.

Note 1: “ * ” denotes reference to explanatory material available in the Annex to this document.



AMD 013 | Weight Distribution Measurements – 2019

S1. SCOPE.

This standard establishes measurement of ambulance weight distribution.

S2. PURPOSE.

The purpose of this standard is to assure vehicle weight is within required limits and proportionally distributed to each wheel. This is a type test.

S3. APPLICABILITY.

This standard applies to all ambulances.

S4. DEFINITIONS.

S4.1 “Curb weight” means the weight of a motor vehicle with standard equipment — maximum capacity of engine fuel, oil and coolant.

S5. REQUIREMENTS.

In the absence of instructions from the chassis manufacturer to the contrary, the following requirements shall apply to all ambulances. The total weight of the vehicle, including all occupants and cargo, shall not exceed the gross vehicle weight rating (GVWR) or any gross axle weight rating (GAWR). Additionally, the vehicle shall not exceed any maximum unloaded vehicle weight limitations specified by the chassis manufacturer. The requirements of S5.2 can be satisfied through actual weights and/or calculated methods. Note: All specifications and requirements of the chassis manufacturer shall take precedence where they may conflict, be more stringent or more complete than the following requirements of this standard.

S5.1 Payload. The curb weight of the completed vehicle shall provide enough payload capacity to meet the minimum value as required for the ambulance type under the current version of KKK-A-1822, unless optional items are ordered by customer. If customer-ordered, optional items are included in the curb weight (i.e., permanently attached equipment), minimum payload values no longer apply and the resulting payload will be communicated to the customer. Curb weight of the completed vehicle shall be verified in accordance with S6, but initial values of payload capacity may be calculated to evaluate customer payload requirements per the specific application.

S5.2 Weight Distribution.

- a. The curb weight of the completed ambulance shall be the same from side to side within 5% on any given axle. When loaded to GVWR:
- b. The weight on each axle shall be within its respective GAWR;
- c. The front to rear weight distribution shall have not less than 20% of the total weight on the front axle, and not less than 50% nor more than 80% on the rear axle; and
- d. The center of gravity of the loaded vehicle must be located in accordance with all stated limitations of the chassis manufacturer.

S6. TEST PROCEDURES.

S6.1 On level ground, determine the amount of curb weight on each wheel end (i.e., “corner weight”) of the completed ambulance.

S6.2 Divide the weight on the left front wheel by the sum of the weights on the left front and right front wheels. Then multiply the number by 100% to obtain the percent of the front axle load carried by the left front wheel.

S6.3 Find the difference between the percent of the front axle load carried by the left front wheel and 50%. Multiply the resulting number by 2 to obtain the percent weight difference between the left front and right front wheels.

S6.4 Use the procedures outlined in S6.2 and S6.3 to determine the percent weight difference on the rear axle.

S6.5 Subtract the total curb weight of the completed vehicle from the GVWR. Verify that the resulting payload capacity is equal to or greater than the minimum required by the current version of KKK-A-1822 or other amount established with the customer. Any permanently attached, optional items of equipment specified by the customer are to be included in the curb weight of the completed vehicle. Any other items of optional equipment (i.e., not permanently attached and/or removable) are to be included in the payload requirement. Use this value for the payload signage required in the current version of KKK-A-1822.



STANDARDIZED TEST METHODS

- S6.6** Using the curb/corner weight information from S6.1, load the vehicle to its GVWR using actual weight or by mathematical weight distribution. The weight of occupants at 175 lbs. shall be calculated or placed at the design H-point of each designated seating position and equivalent location for the patient position. Any optional equipment shall be placed accordingly or combined to a single value and location to represent the effect of the weight. Any remaining cargo capacity shall be evenly distributed from the front occupant compartment through the rear of the patient compartment and/or placed accordingly in cabinets and storage areas or according to customer specific requirements.
- S6.7** Under the loading conditions of S6.6, determine the weight on the front and rear axles and compare each load to the GAWR for each axle. All axle loads shall comply with the front/rear distribution conditions of S5.2 c.
- S6.8** Using the previous information where appropriate, determine the center of gravity location under the conditions set forth by the chassis manufacturer and compare to the limits/conditions set forth in the respective incomplete vehicle document or other appropriate chassis manufacturer publication.



AMD 014 | Engine Cooling System Test – 2019

S1. SCOPE.

This standard verifies performance of the engine cooling system.

S2. PURPOSE.

The purpose of this test is to reduce the possibility of ambulance overheating while operating in a high-temperature environment. This is a type test.

S3. APPLICABILITY.

This standard applies to all ambulances.

S4. REQUIREMENTS.

With the patient compartment and cab air conditioners operating at maximum cooling settings (coldest setting, maximum blower speeds, re-circulating air), engine on high idle, an ambient temperature of 95° F, with a relative humidity of a minimum 40%, and air velocity of at least 5 mph, the cooling system must maintain the engine temperature within the OEM recommended safe operating limits for one hour. If a malfunction warning lamp is illuminated during the test due to excessive engine temperatures, the test is considered failed.

S5. TEST PROCEDURES.

S5.1 Place the ambulance in the hot room. Open all doors: cabinet doors, partition door (if present), patient compartment/cab window (if present) exterior compartment doors and hood.

S5.2 Heat room to 95° F with a minimum relative humidity of 40% and an air velocity of at least 5 mph for three hours.

S5.3 Close all doors, hood, partition door (if present) and patient compartment/cab partition window (if present).

S5.4 Maintain a minimum room air velocity of 5 mph over the vehicle for the duration of the test.

S5.5 Set air conditioners in cab and patient compartment to maximum cooling setting (maximum blower speed, coldest temperature setting, re-circulating air).

S5.6 With all other ambulance equipment off, operate the engine for one hour at a speed not to exceed 1600 rpm for the duration of the test.



STANDARDIZED TEST METHODS

AMD 015 | Ambulance Main Medical Gas System Test – 2019

S1. SCOPE.

This standard establishes testing requirements for the on-board medical gas system.

S2. PURPOSE.

The purpose of this standard is to minimize the possibility of a medical gas system leak and to demonstrate adequate flow through the medical gas outlets. Each vehicle shall be tested as noted in (S5).

S3. APPLICABILITY.

This standard applies to all ambulances.

S4. REQUIREMENTS.

S4.1 The medical gas system shall lose no more than 5 psi (34.5 kPa) of pressure in a 2-hour period.

S4.2 *Each outlet shall be capable of delivering at least 3.53 ft³/min (100 L/min) of medical gas.

S4.3 *A label shall be provided near the medical gas tank stating the following: “The integrity of this medical gas system was tested in accordance with AMD 015 and meets the requirements thereof.”

S4.4 The label shall be signed and dated by an authorized representative of the ambulance manufacturer or test agency.

S5 TEST PROCEDURE.

S5.1 Pressure Test. The following steps shall be performed for the pressure test.

1. Ensure that the ambulance temperature has stabilized in an environment between 34°F (1°C) and 110°F (43°C).
2. If equipped, bypass must be open.
3. Charge the system with approximately 80 psi (552 kPa) of test gas.
4. *Close system valves to trap pressure in the lines that contain the vent valve.
5. Record the system pressure with an accuracy of ±1 psi (7 kPa).
6. Allow the system to rest without disturbance for 2 hours.
7. Record the system pressure.

S5.2 Flow Test. The following steps shall be performed for the flow test.

1. Ensure that the ambulance temperature has stabilized in an environment between 34°F and 110°F (1°C and 43°C).
2. Charge the system with test gas regulated to 50 psi ± 2 psi (345 kPa ± 14 kPa).
3. Plug all outlets other than the one being tested.
4. **Measure and record the flow of gas from each outlet using a flowmeter with an accuracy of ±0.18 ft³/min (±5 L/min).
5. Check the electrical continuity between the medical gas system piping and the vehicle to verify that it is grounded

Note 1: “ * ” denotes reference to explanatory material available in the Annex to this document.

Note 2: “ ** ” denotes reference to explanatory item available in the current edition of NFPA 1917 Standard for Automotive Ambulances, Annex A.



AMD 016 | Patient Compartment Lighting Level Test – 2019

S1. SCOPE AND PURPOSE.

This standard verifies performance of ambulance interior lighting. This is a type test.

S2. APPLICABILITY.

This standard applies to all ambulances.

S3. REQUIREMENTS.

S3.1 The patient compartment lighting shall have the two levels of lighting, high and low, at a minimum.

S3.2 In the high setting, the patient compartment floor shall have a minimum of 15 fc of illumination, measured along the centerline of the clear floor.

S3.3 In the high setting, the primary cot shall be provided with a minimum of 35 fc of illumination, measured on at least 90 percent of the cot's surface area.

S3.4 In the low setting, the patient compartment floor shall have a minimum of 3.5 fc of illumination, measured along at least 85 percent of the centerline length.

S3.5 In the low setting, the side entry step shall have a minimum of 2.0 fc of illumination, measured in the center of the step area.

S3.6 Compliance of the requirements in S3.2 through S3.5 shall be validated by testing a substantially similar ambulance in accordance with S4.

S4. TEST PROCEDURE.

The following steps shall be performed for the patient compartment lighting level test:

1. Prepare the ambulance or locate it in an environment to prevent light from penetrating into the patient compartment.
2. Remove the patient cot.
3. Start the engine.
4. Turn on dome lights to highest setting.
5. Measure and record the light intensity along the longitudinal centerline of the patient compartment floor every 10 in. (254 mm).
6. Turn on the lights that come on with the side entry door or rear entry door.
7. *Measure and record the light intensity along the longitudinal centerline of the patient compartment floor every 10 in. (254 mm).
8. Measure and record the light intensity in the center of the side entry step well and record the reading.
9. Install the patient cot test grid shown in Figure 1, 17 in. (432 mm) above the patient compartment floor, centered laterally and longitudinally on the expected center of the patient cot as it will be secured in the patient compartment.
10. Measure and record the light intensity in the center of each 5 in.2 (322 mm²) area on the test grid.

Note 1: “*” denotes reference to explanatory material available in the Annex to this document.

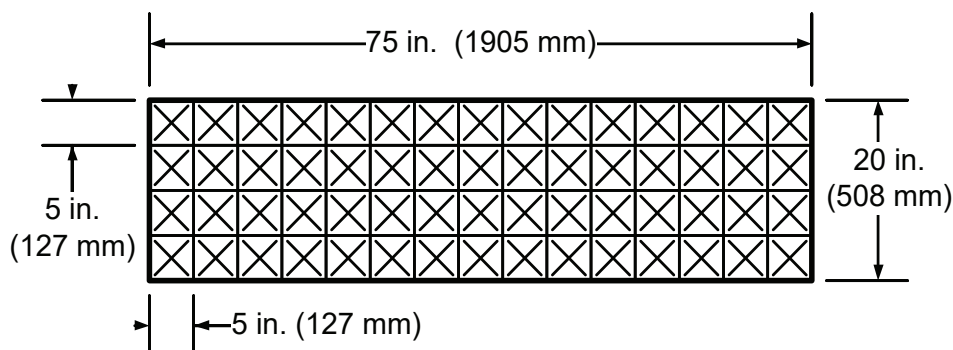

Figure 1 | Patient Cot Test Grid, Top View



AMD 017 | Road Test – 2019

S1. PURPOSE AND SCOPE.

This standard verifies ambulance road performance. This is a type test.

S2. APPLICABILITY.

This standard applies to all ambulances.

S3. DEFINITIONS.

S3.1 “Curb Weight” is the total weight of the complete ambulance and is defined as chassis (including batteries and any other permanently attached or dedicated equipment); cab; body and a full complement of fuel, lubricants and coolant.

S3.2 “Payload Allowance” is the minimum payload for the vehicle as specified in the governing standard.

S3.3 “Cross-Country Operation” is defined as travel over open fields, rolling hills, rough and muddy terrain.

S4. REQUIREMENTS. The ambulance shall be capable of meeting the requirements set forth under this standard when tested in accordance with test procedures outlined in S6. under the conditions set forth in S5.

S4.1 Speed. The vehicles shall be capable of a sustained speed of not less than 65 mph over dry, hard-surfaced, level roads, at sea level, and passing speeds of 70 mph.

S4.2 Acceleration. Vehicle shall have a minimum average acceleration at sea level of 0–55 mph within 25 seconds.

S4.3 Gradeability. The vehicle shall be capable of meeting the following requirements. The determination shall be made by actual test or chassis manufacturer’s certified computer prediction or chassis manufacturer’s certification.

- a. Minimum gradeability at speed shall be 55 mph on a 3% (1.72 degrees) grade.
- b. The minimum low speed gradeability of 5 mph on a 35% (19.3 degrees) grade is required for 4x2 vehicles.
- c. The minimum low-speed gradeability of 5 mph on a 45% (24.2 degrees) grade for 4x4 vehicle in the low 4x4 range.

S4.4 Fuel Range. The ambulance shall be capable of being driven for at least 250 miles without refueling.

S4.5 Fording. The vehicle shall be capable of three fordings, without water entering patient and equipment compartments while being driven through a minimum of 8" of water, at speeds of 5 mph, for a distance of at least 100'.

S5. TEST CONDITIONS.

The following conditions apply.

S5.1 Road test may be performed at any ambient temperature.

S5.2 Vehicle must be loaded to curb weight plus total usable payload (i.e., GVWR), or if specified by the customer, to the prescribed curb weight plus the minimum payload allowance for the type of vehicle being tested as listed in S3.2.

S6. TEST PROCEDURE.

S6.1 The vehicle shall be subjected to a minimum 150-mile road test.

- a. Seventy-five (75) miles shall be continuous miles on paved highways at speeds up to 70 mph.
- b. Thirty (30) miles on city streets.
- c. Fifteen (15) miles on gravel or dirt roads at speeds up to at least 35 mph.
- d. Not less than five miles in simulated or actual cross-country operation at speeds applicable to the terrain.
- e. 4x4 vehicles shall demonstrate cross-country operation in four-wheel drive for an additional 20 miles.
- f. Balance of the 150-mile road test may be accumulated during other tests and checks requiring vehicle movements.
- g. After completion of the road test, vehicle shall be subjected to the water spray test (AMD Standard 010).



AMD 018 | Rear Stepping Surface Load Test – 2019

S1. SCOPE AND PURPOSE.

This standard establishes the minimum requirements for testing an ambulance rear step while the ambulance is not in motion. This is a type test.

S2. APPLICABILITY.

This standard applies to all ambulances.

S3. REQUIREMENTS.

S3.1 The rear stepping surface shall withstand a load of 500 lb (227 kg) with no more than 1.0 in. (25.4 mm) of deflection or 0.25 in. (6.4 mm) of permanent deformation.

S3.2 Compliance of the rear step surface shall be validated by testing a substantially similar ambulance or bumper and step structure in accordance with S4.

S4. TEST PROCEDURE.

The following steps shall be performed during the rear stepping surface load test.

1. Support the ambulance or substantially similar structure to negate the effect of the vehicle suspension.
2. Apply a vertical load on the stepping surface using a fixture that distributes the load over a circular area 5 in. (127 mm) in diameter.
3. Apply 500 lb (227 kg) of load to the lateral and longitudinal center of the stepping surface.
4. Record deflection during the load application.
5. Release the load.
6. Measure and record any permanent deformation after the load is released.
7. Apply 500 lb (227 kg) of load to the longitudinal center of the stepping surface as close to each of the lateral extremes as the test fixture will allow.
8. Record deflection during the load application.
9. Release the load.
10. Measure and record any permanent deformation after the load is released.



AMD 019 | Cabinet & Compartment Measurements – 2019

S1. SCOPE AND PURPOSE.

This standard establishes guidelines for accurately measuring the volume of interior cabinets and exterior compartments of an ambulance.

S2. APPLICABILITY.

This standard applies to all ambulances.

S3. DEFINITIONS.

S3.1 “Cabinet depth” is the measured depth from the cabinet inside back wall to the outside cabinet face.

S3.2 “Compartment depth” is the measured depth from the compartment inside back wall to the outside compartment face.

S3.3 “Door OD” is the door overall outside thickness (dimension).

S3.4 “Depth ID” is the actual interior depth either measured or figured by subtracting the Door OD from the cabinet or compartment measured depth.

S3.5 “Height ID” is determined by measuring from interior bottom surface to the interior surface of the cabinet or compartment top.

S3.6 “Width ID” is determined by measuring from one interior surface to the next interior surface of the cabinet or compartment.

S3.7 “Sliding window track” is the track used for sliding cabinet windows.

S3.8 “Sliding cabinet windows” is the sliding doors used on interior cabinets.

S4. TEST CONDITIONS.

S4.1 Remove any loose or mounted removal able equipment from interior cabinets or exterior compartments. Examples would be fire extinguishers, portable oxygen mounts, spare tires and tools.

S5. TEST PROCEDURE.

S5.1 Interior cabinet with sliding doors or roll-up doors (Figure 1).

- a. Measuring from the back of the rear wall to the back of the sliding window track, record that dimension for Depth ID.
- b. Measuring from cabinet interior wall to wall, record that dimension for Width ID.
- c. Measuring from the interior top to bottom, record dimension. This is the Height ID.
- d. Multiply Height ID x Width ID x Depth ID = then divide by 1,728 to get cubic feet.

S5.2 Interior cabinets with hinged doors (Figure 2).

- a. Measure from the back of the door to the face of the door and record that dimension for Door OD.
- b. Measure from the back of the rear wall to the cabinet face and record that dimension for cabinet depth.
- c. Subtract the Door OD from the cabinet depth to get Depth ID.
- d. Measure from cabinet interior wall to wall and record that dimension for Width ID.
- e. Measure from the interior top to bottom and record dimension. This is the Height ID.
- f. Multiply Height ID x Width ID x Depth ID = then divide by 1,728 to get cubic feet.

S5.3 Exterior Compartments with hinged doors (Figure 3).

- a. Measure from the back of the door to the face of the door and record that dimension for Door OD.
- b. Measure from the back of the rear wall to the cabinet face and record that dimension for cabinet depth.
- c. Subtract the Door OD from the cabinet depth to get Depth ID.
- d. Measure from cabinet interior wall to wall and record that dimension for Width ID.
- e. Measure from the interior top to bottom and record dimension this is the Height ID.
- f. Multiply Height ID x Width ID x Depth ID = then divide by 1,728 to get cubic feet.

Note: Subtract any notches for spring shackles or fuel systems from the total to get the correct total cubic feet.



STANDARDIZED TEST METHODS

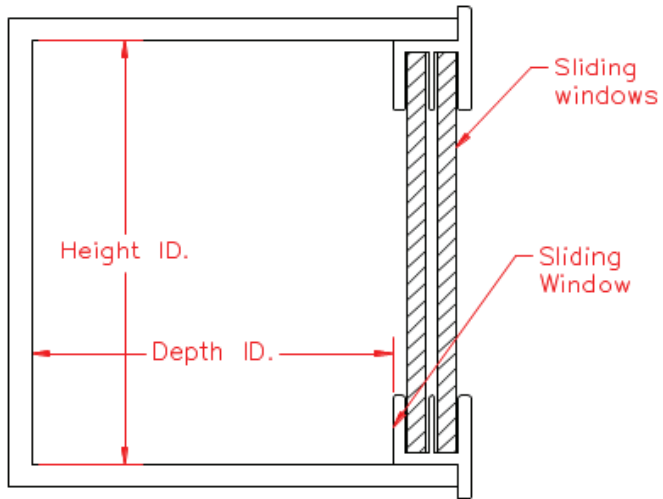

Figure 1

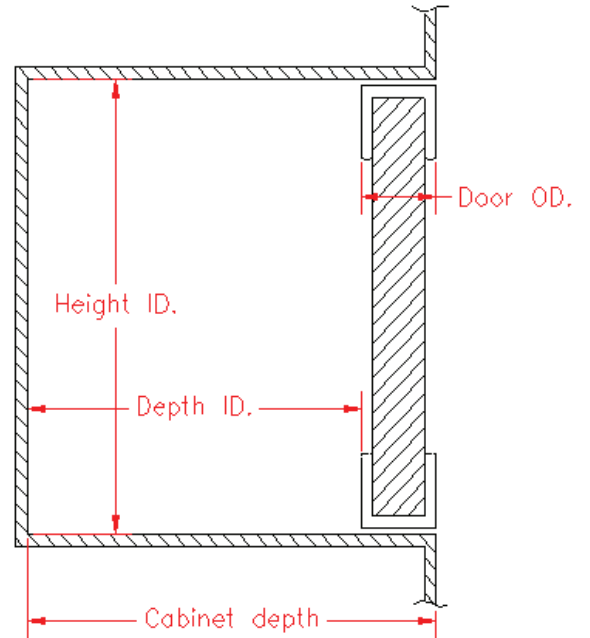

Figure 2

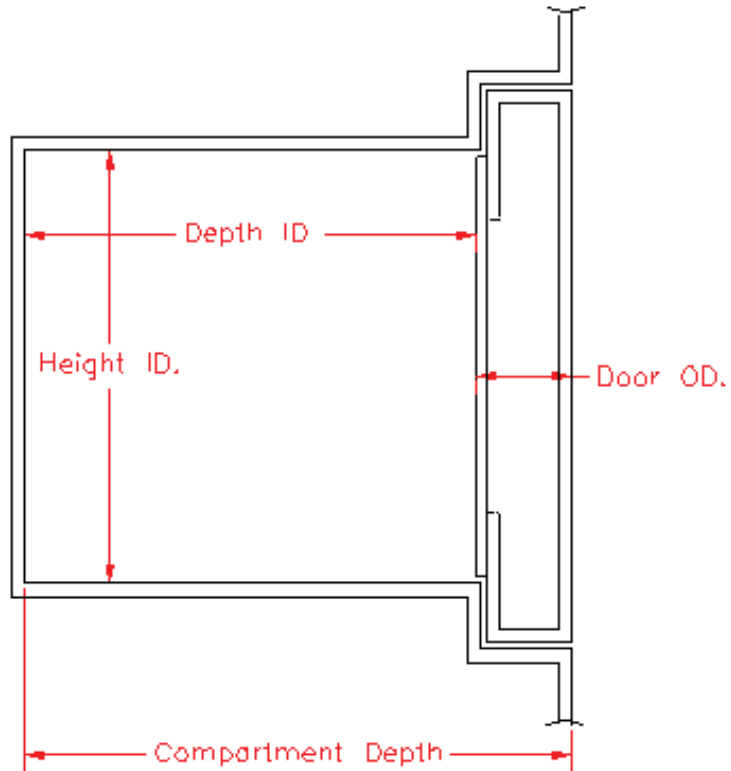

Figure 3



AMD 020 | Floor Distributed Load Test – 2019

S1. SCOPE.

This standard establishes the minimum testing requirements for verifying patient compartment floor weight bearing capacity.

S2. PURPOSE.

The purpose of this standard is to validate that the weight bearing capacity of the ambulance floor can support the weight of the laden cot. This is a type test.

S3. APPLICABILITY.

This standard applies to all ambulances.

S4. DEFINITIONS.

S4.1 “Distributed loads.” Medium footprint of existing cots loaded to required test load of 400 lbs. for a standard cot or 800 lbs. for a bariatric cot.

S4.2 “Standard cot load” is designed to handle a cot load of 400 lbs.

S4.3 “Bariatric cot load” is designed to handle a cot load of 800 lbs.

S4.4 “Load Cell,” as shown in Figure 1 on page 25, is loaded to either a standard cot load of 400 lbs. or a bariatric cot load of 800 lbs.

S4.5 “Deflection Indicator,” as shown in Figure 2 on page 25, used to measure floor deflection as close to centerline of the load cell and wheels as possible.

S5. REQUIREMENTS.

With a load for either a standard cot or bariatric cot applied to the floor structure as specified in S7., the allowable maximum deflection is $\frac{1}{16}$ -inch for standard cot and $\frac{1}{8}$ -inch for a bariatric cot. If flooring material has a raised pattern, measure the pattern and subtract from any deflection.

S6. TEST CONDITIONS.

S6.1 The test may be conducted at any temperature with the vehicle parked on a level surface.

S7. TEST PROCEDURE.

Each vehicle tested shall be capable of meeting the requirements of S5. when tested in accordance with the procedures set forth below.

- a. Locate load cell on centerline of floor (measured from left wall to squad bench) and flush with inside of rear doors (see Figure 3 on page 25).
- b. Load cell to required load (400 lbs. or 800 lbs.).
- c. Using Deflection Indicator, measure floor deflection at centerline of each wheel along load cell axis (four points B, C, E and F).
- d. Using Deflection Indicator, measure floor deflection across (22") the front and rear of the load cell at centerline of floor (two points A and D).
- e. Move load cell forward 12" and repeat procedures C and D.
- f. Continue moving load cell forward and recording deflection at six points until 12" from front seat cushion.



STANDARDIZED TEST METHODS

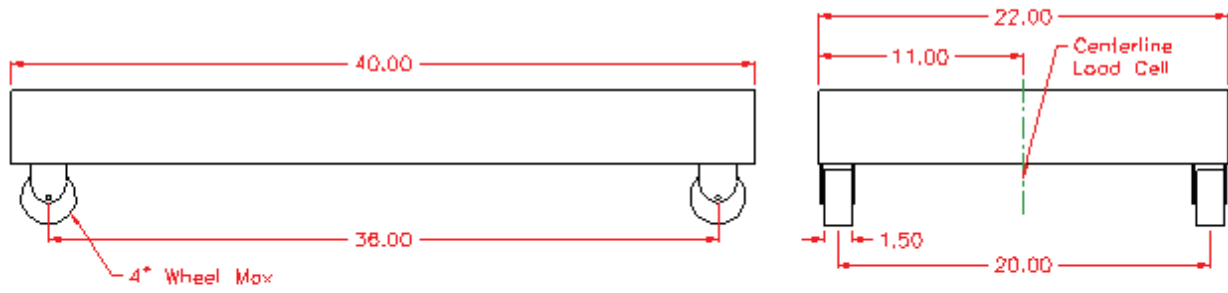

Figure 1 | Load Cell

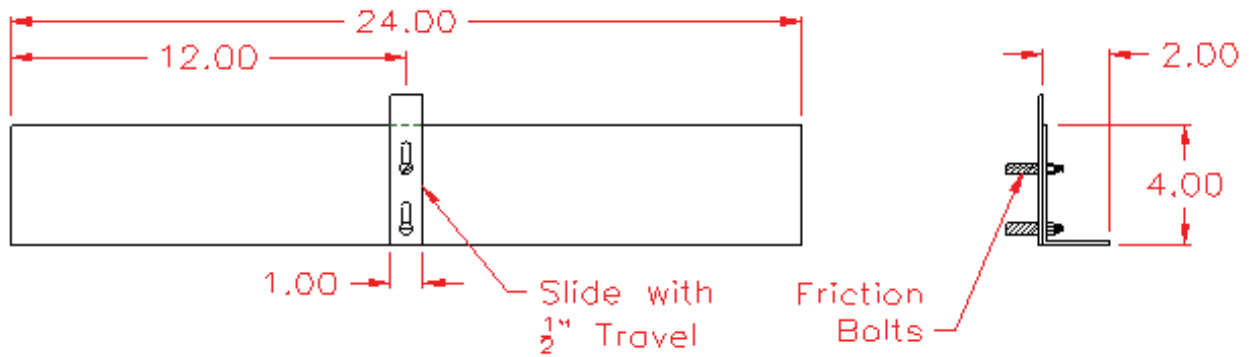

Figure 2 | Deflection Indicator

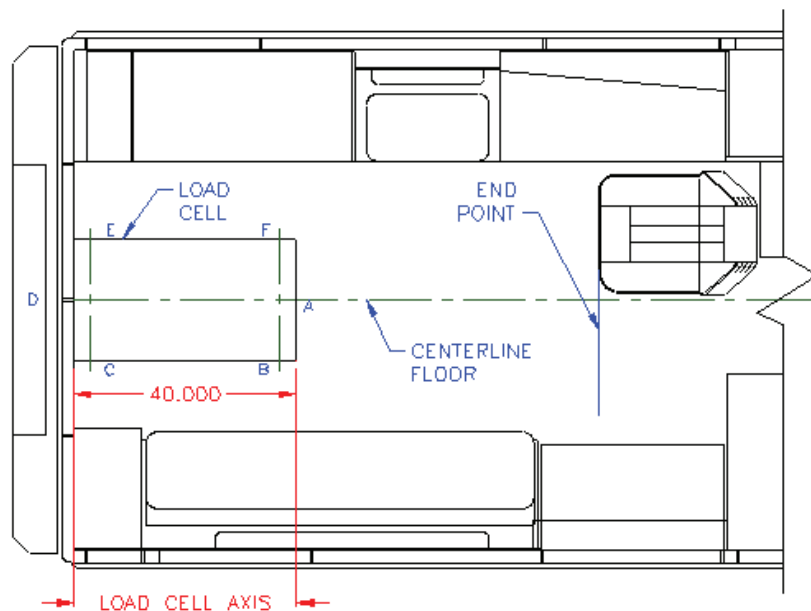

Figure 3



AMD 021 | Aspirator System Test – 2019

S1. SCOPE.

This standard verifies performance of an ambulance Aspirator System, Primary Patient, when installed per the manufacturer's directions. Each finished vehicle shall be tested.

S2. PURPOSE.

The purpose of this standard is to ensure that minimum performance levels are attained that will permit collection of aspirate and semi-solid gastric stomach contents.

S3. REQUIREMENTS.

S3.1 The aspirator system shall provide a free airflow of at least 30 L/min.

S3.2 The aspirator system shall achieve a minimum of 300 mm Hg vacuum within 4 seconds after the suction tube is closed.

S3.3 Compliance of the aspirator system shall be validated by the manufacturer by testing each individual aspirator system installed in accordance with S4.

S4 TEST PROCEDURE.

The following steps shall be performed during the aspirator system test:

1. Ensure that the ambulance temperature has stabilized in an environment between 34°F and 110°F (1°C and 43°C).
2. Run the vehicle engine at high idle speed for duration of the test.

S4.1 Vacuum Test. The following steps shall be performed during the vacuum test.

1. Attach a 120 in. (3 m) length of transparent or translucent, non-kinking suction tubing to the collection bottle.
2. Install a vacuum-measuring instrument capable of an accuracy of ± 10 mm Hg (± 1.3 kPa) to measure the vacuum in the collection bottle.
3. Adjust the vacuum control valve to its maximum vacuum position.
4. Turn on the vacuum pump.
5. Clamp or plug the end of the suction tubing.
6. Measure and record the vacuum 4 seconds after plugging the tubing.

S4.2 Flow Test.

The following steps shall be performed during the flow test.

1. Install a flow-measuring instrument capable of an accuracy of ± 0.18 ft³/min (5 L/min) to measure the flow in the suction tubing.
2. Adjust the vacuum control valve to its maximum vacuum position.
3. Turn on vacuum pump.
4. Measure and record the flow.



STANDARDIZED TEST METHODS

AMD 022 | Cold Engine Start Test – 2019

S1. SCOPE.

This standard verifies the ambulance engine starting performance requirements.

S2. PURPOSE.

The purpose of this standard is to reduce the possibility of the engine failing to start in a cold environment. This is a type test.

S3. APPLICABILITY.

This standard applies to all ambulances.

S4. REQUIREMENTS.

The engine shall start without the use of external power or starting fluids. The engine shall start satisfactorily without the aid of engine block preheating devices (except glow plugs or combustion air pre-heater) at 0° F. The determination shall be by actual test, cooperative testing through AMD or by chassis manufacturer's certification.

S5. TEST CONDITIONS.

- S5.1** The ambulance shall have all patient compartment doors, cabinet doors, cab doors, hood and exterior compartment doors open throughout S6.3.
- S5.2** Air velocity of at least 5 mph shall be maintained over the vehicle throughout the entire test.
- S5.3** The test chamber must be capable of maintaining temperature within a tolerance limit of +/- 4° F for the duration of the test.

S6. TEST PROCEDURE.

- S6.1** Place the ambulance in the cold room. Turn off all power. Open all doors and hood. If in the case of cab dome lights being on, roll the cab windows all the way down.
- S6.2** Two exterior thermocouples are to be placed on the centerline of the vehicle, halfway between the ground and the highest point of the vehicle (excluding bolt-on items), 36" forward of the front extremity of the vehicle and 36" rear of the rear extremity. Reference Figure 1 on page 28. This requirement shall also hold the same +/- 4° F tolerance.
- S6.3** Cool to 0° F with an air velocity of at least 5 mph for three hours.
- S6.4** Close all doors, hood, partition door (if present) and patient compartment/cab partition window (if present) and start engine. Engine must run for five minutes without stalling.



STANDARDIZED TEST METHODS

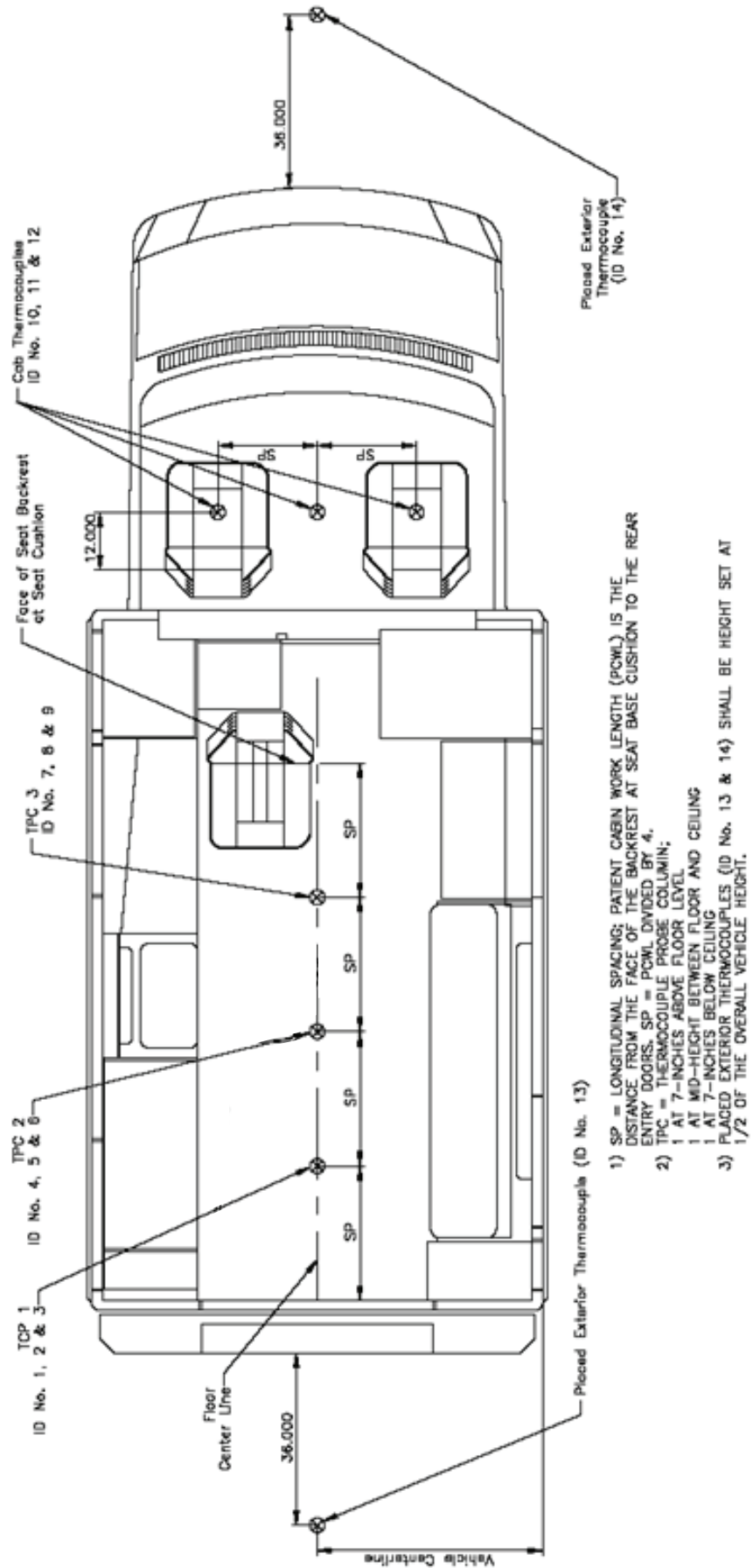

Figure 1



AMD 023 | Siren Performance Test – 2019 rev. 1

S1. SCOPE.

This standard verifies performance of an ambulance siren. This is a type test.

S2. PURPOSE.

To provide a testing method that validates the performance, installation, and speaker location of the siren system. If a component of the siren system changes, the location of the siren speakers is altered, or a feature is added or modified (e.g., a front grille guard), this test must be repeated to validate conformance of the new system.

S3. TEST PROCEDURE.

S3.1 This test shall be performed during the meteorological conditions determined by the governing standard and the following should be recorded:

- (a) Date and time;
- (b) Location of test performed (address);
- (c) Model, type, and serial number of the vehicle tested;
- (d) Pictures of the testing setup, including the front of the vehicle;
- (e) Direction vehicle is facing versus wind;
- (f) Temperature;
- (g) Humidity;
- (h) Wind speed; and
- (i) Ambient decibel level at the recording point in front of the vehicle.

S3.2 Park the vehicle on a concrete or asphalt surface at a location that has no large reflecting surfaces, such as other vehicles, signboards, buildings, or hills, within 50 ft (15 m) in any direction of the vehicle being tested.

S3.3 Start the vehicle and set the high idle speed (RPM shall not exceed the OEM recommended high idle speed).

S3.4 Close the vehicle doors, windows, and vents.

S3.5 Using a sound level meter that meets the requirements of S1.4 of the American National Standards Institute (ANSI), Specification for Sound Level Meters, for Type II meters (operating on the A-weighting network with a slow meter response), record decibels levels as specified in S3.6, below, of the siren speaker system at a point that is (on a horizontal plane) 10 ft (3 m) forward of the centerline of the vehicle's hood and 3 ft (1 m) above ground level.

S3.6 Operate the siren through all modes while recording the maximum decibel level for each mode. For each mode, repeat until two maximum sound levels within 2 decibels (dB) of each other are recorded. Numerically average these two maximum sound level readings.

S4. TEST ACCEPTANCE CRITERIA.

S4.1 The siren shall be capable of producing a warning sound at a minimum level/mode as determined by the governing standard.



AMD 024 | Perimeter Illumination Test – 2019

S1. SCOPE.

This standard verifies performance of ambulance perimeter lighting intensity.

S2. PURPOSE.

The purpose of this standard is to measure and verify the exterior lighting provided for the sides and rear of ambulances. This is a type test.

S3 REQUIREMENTS.

S3.1 The perimeter area shall be illuminated to a level of at least 1 footcandle (fc) at each measuring point.

S3.2 Compliance of the lighting illumination shall be validated by testing a substantially similar ambulance in accordance with S4.

S4 TEST PROCEDURE.

The following steps shall be performed during the perimeter illumination test.

1. Place the ambulance in a dark environment.
2. Ensure that the vehicle batteries are fully charged.
3. Record the light intensity with a meter capable of measuring to an accuracy of ± 0.01 fc.
4. Construct a grid of test points off the sides and rear of the test ambulance, as shown in Figure 1.
 - a. Locate lines parallel with the exterior walls of the patient compartment 60 in. (1 524mm) and 120 in. (3 048 mm) from the test unit.
 - b. Intersect these lines with lines perpendicular to the exterior walls emanating from each corner and with equally space lines, one at the midpoint of the patient compartment for the back of module, and two (2) equally space lines for the sides, as shown in Figure 1 on page 31.
- 5) Measure and record the light intensity at each test point in the grid.
- 6) Turn on all exterior scene lights.
- 7) Measure and record the light intensity at each point 3 in. (76 mm) above the grid.
- 8) Subtract the ambient light readings from the scene light readings.

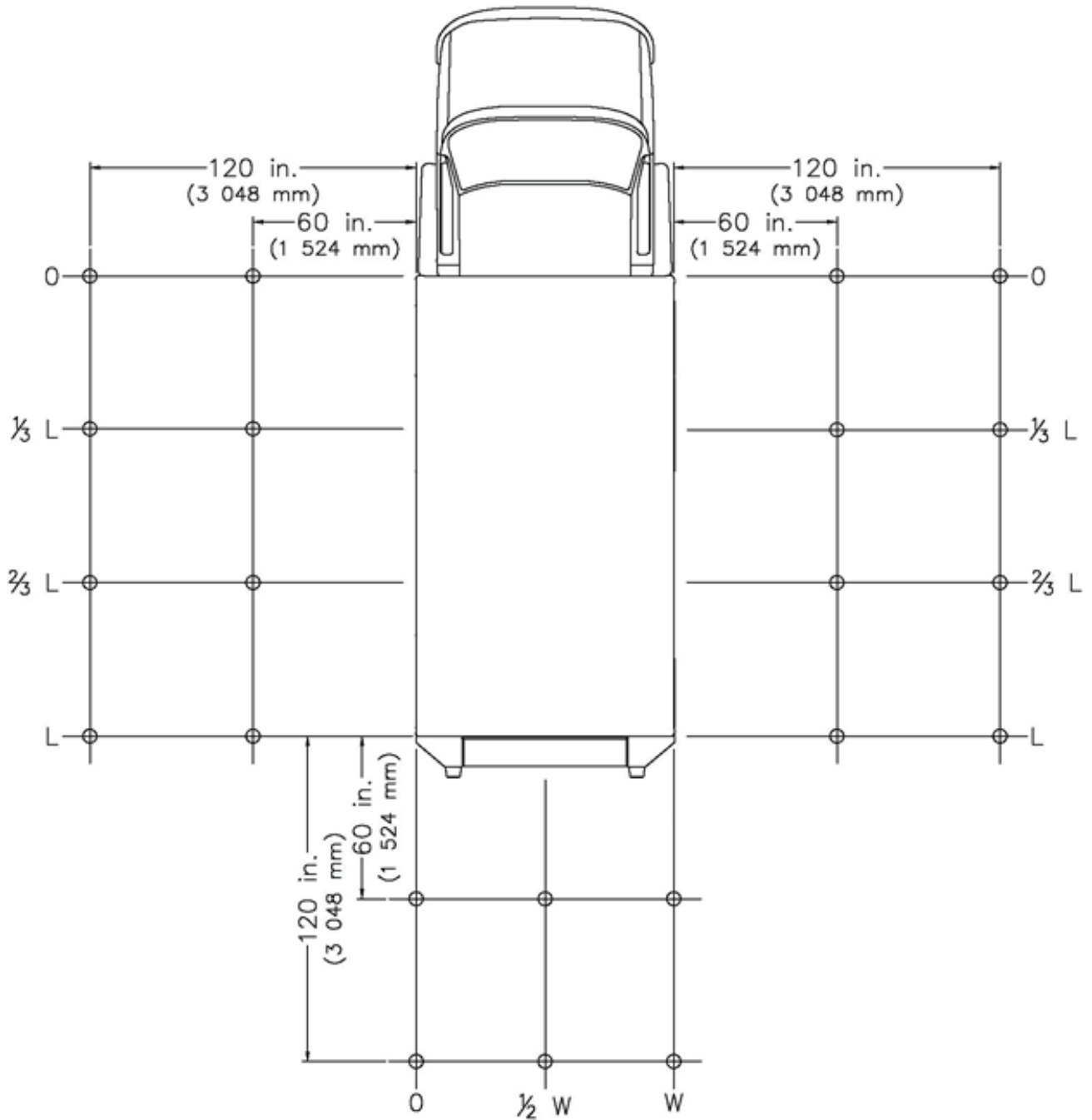

Figure 1 | Perimeter Illumination Test Grid



STANDARDIZED TEST METHODS

AMD 025 | Occupant Head Clearance Zones Test – 2019

S1. SCOPE.

This standard establishes the requirements for measuring the minimum acceptable dimension for an occupant workspace based on static considerations.

S2. PURPOSE.

The purpose of this standard is to ensure that measurement of the occupant workspace is performed correctly. Each finished vehicle shall be tested.

S3. REQUIREMENTS.

S3.1 The minimum seat-to-ceiling dimension from the top surface of the seat bottom cushion to the nearest overhead obstruction for each designated seating position shall be 43 in. (1092 mm).

S3.2 The measurement shall be in accordance with the procedures in S4.

S4 TEST PROCEDURES.

S4.1 The following steps shall be performed during the occupant head clearance zones test:

1. Construct a rigid rectangular test box 43 in. (1092 mm) high, 24 in. (457 mm) wide, and 15 in. (381 mm) deep.
- 2) Place the test box in each seating position, centered laterally on the seat cushion, with the bottom edge resting against the seat back.
3. Align the test box so that the sides of the box are perpendicular to the patient compartment floor.

S4.2 The maximum weight for the test fixture shall not exceed 60 lb (27 kg).

S4.3 No permanent objects shall protrude into the test box zone.



AMD 026 | Ambulance Emergency Lighting System Configuration – 2019

S1. SCOPE AND PURPOSE.

This standard validates performance requirements for ambulance emergency lighting systems. The purpose of this standard is to establish testing and certification procedures for the ambulance emergency lighting system.

S2. APPLICABILITY.

This standard applies to all ambulances.

S3. DEFINITIONS.

S3.1 “Section” means the applicable section of the current version of Federal Specification for the Star-of-Life Ambulance, KKK-A-1822.

S4. REQUIREMENTS.

Each ambulance shall be tested.

S5. TEST PROCEDURES.

S5.1 PHOTOMETRIC, CHROMATICITY, AND PHYSICAL REQUIREMENTS.

Each emergency light shall flash 75 to 125 times per minute. The chromaticity values of the lights shall conform to SAE J578, for their respective color, except for the red lights, which may conform to the following expanded boundary limits of: $y = 0.34$; $y = 0.32$; $x = 0.62$. All warning lights shall project a beam spread of at least 5° up and 5° down and at least 45° left and right of H-V. Each light shall produce flash energy, (Cd-s) per flash, measured from the H-V to all the extreme test point coordinates and shall be tested at all 5° increments. At no point shall the Cd-s values drop to less than the minimum values as shown in Table 1 when tested at 14.2 volts. Flash energy shall be determined in accordance with the SAE J845 method for determining the flash energy of a light. Testing shall be conducted on the device(s) as manufactured including use of the actual light source and all other related system components.

S5.2 The engine will be started and set to at an engine speed not to exceed 1600 rpm in order to maintain the system voltage between 13.0 and 14.5 volts for the duration of the test.

S5.3 Immediately following warm-up, emergency lighting shall be turned on. If the ambulance is equipped with a load management system that inhibits certain systems and loads from operating under certain conditions, ambulance shall be put into the condition that will allow the maximum electrical load.

S5.4 TESTS, WARNING LIGHT SYSTEM.

The lighting manufacturers shall furnish and certify or the FSAM shall measure and record the total average current load of the standard emergency warning light system on the vehicle as manufactured at the regulated voltage of 14.2 volts, when operated in the mode which draws maximum current. The warning light system and related components and devices shall be tested and approved by an Automotive Manufacturers Equipment Compliance Agency (AMECA) accredited laboratory and listed with the AMECA for compliance with the requirements in this specification.

S5.5 EMERGENCY LIGHTING SYSTEM CONFIGURATION.

The ambulance standard emergency warning light system shall contain twelve fixed red lights, one fixed clear light and one fixed amber light. These lights shall function in a dual mode system as shown in Table 1 and meet the physical and photometric requirements. The upper body warning lights shall be mounted at the extreme upper corner areas of the ambulance body, below the horizontal roofline. The single clear light shall be centered between the two front-facing, red, upper corner lights or in a dedicated housing mounted forward of the body on the cab roof. If due to limited body dimensions and physical size of the outboard forward-facing lights, the lights may also be mounted in dedicated housings on the cab roof. Doors or other ancillary equipment shall not obstruct the standard warning lights. The amber light shall be symmetrically located between the two rear-facing red lights. The red “grille” lights shall be located at least 30" above the ground and below the bottom edge of the windshield and be laterally separated by at least 18", measured from centerline to centerline of each lamp. The lateral facing intersection lights shall be mounted as close as possible to the front upper edge of each front fender and may be angled forward a maximum of 30°. All warning lights furnished shall be mounted to project their highest intensity beams on the horizontal plane. Alternate approved lighting systems are NFPA 1901 compliant or SAE J2498 compliant.



STANDARDIZED TEST METHODS

- S5.6** The FSAM shall examine the ambulance to determine that the flash pattern and flash rate are in compliance with section 3.8.2.2 and Table 1. A certification of compliance from the lighting manufacturer for the flash rate of the flashing sequencer (75 to 125 flashes per minute) shall be acceptable.
- S5.7** The primary and secondary modes shall be tested to determine that they perform as required by Table 1 on page 35.
- S6. TEST CONDITIONS.**
The following conditions apply to the requirements specified in S5.
- S6.1** Ambulance and component systems shall be complete and ready to operate on the road.
- S6.2** Temperature. Engine shall be started and allowed to operate until normal engine temperature is reached then allowed to operate an additional 15 minutes.
- S6.3** Batteries. Batteries shall be fully charged at the beginning of the test.
- S7. CERTIFICATION.**
- S7.1** The reading recorded in S5.4 shall be recorded. The load shall not exceed 40 Amperes.



STANDARDIZED TEST METHODS

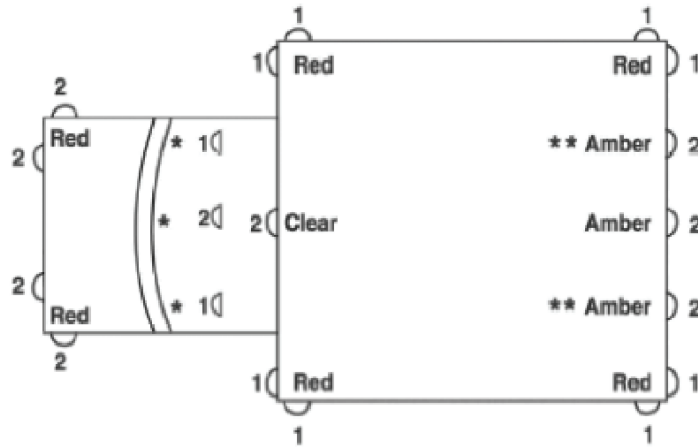

FLASH PATTERN

* Optional forward facing light locations on cab roof for two red and single center clear lights.

** Optional rear amber lights in lieu of single center light.

1 - Indicates lights flashing at the same time.
2 - Indicates lights flashing 180 degrees out of phase with 1.

MINIMUM FLASH ENERGY, Cd-S PER FLASH, PER FIXTURE				
COLOR	RED		CLEAR	AMBER
LOCATION	GRILL & FENDERS	UPPER BODY CORNERS	FRONT CENTER	REAR CENTER*
DAY	160 Cd-S @ HV	240 Cd-S @ HV	900 Cd-S @ HV	600 Cd-S @ HV
	80 Cd-S @ $\pm 5^\circ$ H Points	120 Cd-S @ $\pm 5^\circ$ H Points	450 Cd-S @ $\pm 5^\circ$ H Points	300 Cd-S @ $\pm 5^\circ$ H Points
	12 Cd-S @ All 5° V - 45° H Points	32 Cd-S @ All 5° V - 45° H Points	96 Cd-S @ All 5° V - 45° H Points	72 Cd-S @ All 5° V - 45° H Points
NIGHT	10 - 30% of the above			

* Single center rear or combined dual rear (Optional)

MODAL EMERGENCY LIGHTING SYSTEM				
COLOR & LOCATION	RED	CLEAR	AMBER	RED
	Front and Rear Corners	Front Upper Center	Rear Center	Grille and Fender
PRIMARY "Clear the Right-of-Way"	ON	ON	ON	ON
SECONDARY "Hazard-Vehicle Stopped on Right-of-Way"	ON	OFF	ON	OFF

TABLE 1 | Emergency Lighting



STANDARDIZED TEST METHODS

AMD 027 | Line Voltage Electrical Systems Test – 2019

S1. SCOPE AND PURPOSE.

This standard establishes test requirements for ambulances and equipment installed within or on ambulances and the conductors that connect ambulances to 125-volt, nominal, AC electrical supply system(s).

S2. APPLICABILITY.

This standard applies to all ambulances

S3 REQUIREMENTS.

S3.1 The wiring and associated equipment shall be tested by the ambulance manufacturer or the installer of the line voltage system.

S3.2 The electrical polarity of all permanently wired equipment, cord reels, and receptacles shall be tested to verify that wiring connections have been properly made.

S3.3 Electrical continuity shall be verified from the chassis or the body to all line voltage electrical enclosures, light housings, motor housings, light poles, switch boxes, and receptacle ground connections that are accessible to personnel in normal operations.

S3.4 If the ambulance is equipped with a transfer switch, it shall be tested to verify operation and that all non-grounded conductors are switched.

S3.5 Electrical light towers, floodlights, motors, fixed appliances, and portable generators shall be operated at their full rating or capacity for 30 minutes to ensure proper operation.

S3.6 CERTIFICATION TEST OF POWER SOURCE.

S3.6.1 The ambulance manufacturer or installer of the power source shall perform a certification test on each power source.

S3.6.2 The testing of any power source greater than 8 kW shall be witnessed, and the results of the tests of the power source shall be certified by an independent third-party certification organization.

S4 TEST PROCEDURE.

S4.1 The prime mover shall be started from a cold start condition, and the unloaded voltage and frequency shall be recorded.

S4.2 The line voltage electrical system shall be loaded to at least 100 percent of the continuous rated wattage stated on the power source specification label.

S4.3 Testing with a resistive load bank shall be permitted.

S4.4 The power source shall be operated in the manner specified by the ambulance manufacturer as documented on instruction plates or in operation manuals.

S4.5 The power source shall be operated at a minimum of 100 percent of the continuous rated wattage as stated on the power source specification label for a minimum of 2 hours.

S4.5.1 The load shall be adjusted to maintain the output wattage at or above the continuous rated wattage during the entire 2-hour test.

S4.5.2 The following conditions shall be recorded at least every 30 minutes during the test.

1. The power source output voltage, frequency, and amperage
2. The prime mover's oil pressure, water temperature, and transmission temperature, if applicable
3. The power source hydraulic fluid temperature, if applicable
4. The ambient temperature and power source air inlet temperature



STANDARDIZED TEST METHODS

- S4.5.3** The following conditions shall be recorded once during the test for power sources driven by dedicated auxiliary internal combustion engines.
- 1) Altitude
 - 2) Barometric pressure
 - 3) Relative humidity
- S4.6** If the generator is driven by the chassis engine and the generator allows for operation at variable speeds, the chassis engine speed shall be reduced to the lowest rpm allowed for generator operation, and the voltage and frequency shall be recorded.
- S4.7** The load shall be removed, and the unloaded voltage and frequency shall be recorded.
- S4.8** Voltage shall be maintained within ± 10 percent of the voltage stated on the power source specification label during the entire test.
- S4.9** Frequency shall be maintained within ± 3 Hz of the frequency stated on the power source specification label during the entire test.
- S4.10** Inverter Test. If the ambulance has an inverter, then the ambulance inverter shall be tested as follows:
1. The ambulance engine shall be running during the inverter test.
 2. The inverter shall be subjected to a load equal to the manufacturer's nominal listed power output for a minimum of 1 hour.
 3. If the manufacturer has a specific full power output test, that test shall be performed.
 4. A load bank shall be permitted to be used.
 5. The test shall be considered a failure if the output of the inverter drops below the manufacturer's specifications or more than 10 percent of nominal listed output.
- S4.11** On-Board Battery Charger Test.
- The ambulance on-board battery charger shall be tested for 2 hours as follows:
1. Batteries shall be fully charged to at least 12.66 volts before starting test.
 2. Engine off and shoreline power cord attached.
 3. Apply a load of at least 80% of nominal charger output.
 4. Inverter/battery charger compartment closed.
 5. Record battery voltage at beginning of test.
 6. Remove the load and record battery voltage at end of test.
 7. The battery charger test shall be considered a failure if charger does not maintain battery voltage at 12.54 volts or higher.
- S5.** Non-Mandatory Suggestions and Explanations.
- The purchaser should consider the range of temperatures in which the power source is to be operated. If extreme conditions are anticipated, the purchaser should specify the test conditions that are desired.
- The purchaser should check the polarity of the wiring in a building prior to interconnecting the ambulance-mounted electrical system to the electrical system in a building.
- It is important that the power source meets the purchaser's requirements for output. Power sources may be advertised with power ratings for operating conditions that are more favorable than the conditions that might be encountered in ambulance use. Some power sources are advertised at peak output or intermittent duty ratings and not the continuous duty output required for ambulances. The power source manufacturer and ambulance manufacturer might need to establish a reduced rating that is appropriate for ambulances.
- This standard calls for two steps. First the power source manufacturer provides a declared rating for 120°F (49°C) air inlet temperature and 2000 ft (600 m) altitude for the minimum clearance and ventilation indicated on the declaration. Then the ambulance manufacturer verifies that the rating printed on the power source specification label can be attained during the line voltage load test.



STANDARDIZED TEST METHODS

Generator Set Rating.

Auxiliary engine-powered generator sets are the type of power source most likely to require a reduction from advertised ratings, and generator set literature usually provides rating correction factors for altitude and temperature. These factors could be based on standards for engines, such as ISO 3046-1, Reciprocating internal combustion engines — Performance — Part 1: Declarations of power, fuel and lubricating oil consumptions, and test methods — Additional requirements for engines for general use, and SAE J1349, Engine Power Test Code — Spark Ignition and Compression Ignition — Net Power Rating; standards for generators, such as NEMAMG 1, Motors and Generators; or manufacturer testing. As an example of how altitude and temperature affect output capability, consider a typical 10 kW generator set with 0.8 generator efficiency and naturally aspirated diesel engine that is rated at 500 ft (150 m) and 85°F (30°C) for continuous operation without overload or reserve capacity. ISO 3046-1 indicates a factor of –2.1 percent output per 10°F (5.5°C) ambient increase, and a –2.6 percent per 1000 ft (300 m) altitude increase. Generator output is also affected by temperature [about –0.5 percent per 10°F (5.5°C)] and altitude (small and ignored in this example).

There is also an effect from combining engine and generator into a generator set due to each heating the other. This may require an additional factor of –1 to –4+ percent per 10°F (5.5°C), depending on the effectiveness of the cooling system and temperature (the factor increases with increasing temperature). Altogether, these factors suggest the 10 kW generator set in this example is capable of about 8.8 kW at the maximum temperature of 110°F (43°C) and altitude of 2000 ft (600 m) specified in the standard. Another way to view this result is that an 11.4 kW generator set would be required to provide 10 kW at 110°F (43°C) and 2000 ft (600 m).

Where there is concern that installation or operational circumstances could cause power source intake air to heat above 120°F (49°C) or where the flow of cooling, induction, or exhaust air is more restricted than what is allowed by the manufacturer's literature, advance consultation with the power source manufacturer(s) could help in the selection of a power source that will pass the ambulance test with an output that meets the purchaser's needs. Also, weather, like altitude, also can affect air density and thus engine and generator set output. The combined effect of altitude and weather is reported as barometric pressure on local weather reports. Low barometric pressure will reduce engine and generator set output capability. High barometric pressure (usually clear cold days) will increase engine and generator set output capacity.

Other Power Source Types.

Some output correction factors described in the generator set example apply to other types of power sources, depending on circumstances. For example, PTO and hydraulically driven generators also rely on engine power, but the engine will usually have substantial reserve power, so increased altitude or temperature will not affect their power supply rating. Regardless, best practice for longest life and lowest maintenance is to provide unrestricted airflow at the lowest temperature.



AMD 028 | Vertical Component Retention — Static Test – 2019

S1. SCOPE.

This standard establishes the minimum requirements for verifying vertical retention.

S2. PURPOSE.

The objective of the test is to verify that the Equipment Mounting Device or System retains the Test Analog/Device and remains attached to its test surface when the Test Analog/Device and the Equipment Mounting Device or System are subject to a vertical 25G acceleration. The vertical load shall be upward if the item is floor-mounted, upward and downward if wall-mounted, and downward if ceiling-mounted. Items mounted adjacent to a floor or ceiling are considered floor-mounted or ceiling-mounted, respectively. Items mounted to a counter top are considered to be floor-mounted. This is a type test.

S3. APPLICABILITY.

This standard applies to all components which require testing to SAE J3043.

S4. DEFINITIONS.

S4.1 “Equipment” means the device affixed by way of a separate mount or holder. This includes any permanently attached brackets or hardware that may be required for attachment to the Equipment Mounting Device or System.

S4.2 “Equipment Mounting Device or System” means a retention system that utilizes a temporary or permanent means of fixation, which may have fixed or adjustable positions, for a specific piece of Equipment. Also includes all hardware provided for securing the Equipment.

S4.3 “Test Surface” means the surface to which the Equipment Mounting Device or System is attached for testing.

S4.4 “Test Analog/Device” means a rigid inert structure that represents the physical dimensions of the Equipment for which the Equipment Mounting Device or System was designed to restrain. It provides connection points to attach to the Equipment Mounting Device or System that match those found on the actual Equipment to be mounted in the Equipment Mounting Device or System.

S5. REQUIREMENTS.

S5.1 The Test Surface and means of attaching the Equipment Mounting Device or System used for the test must replicate what is used in actual service conditions.

S5.2 The attachment of the Test Analog/Device to the Equipment Mounting Device or System must withstand a force equal to 25 times the weight of the Equipment.

S5.3 The attachment of the Equipment Mounting Device or System to its test surface must withstand a force equal to 25 times the combined weight of the Equipment and the Equipment Mounting Device or System.

S5.4 The elements listed in S5.2 and S5.3 may be tested independently or as a single assembly.

S6. TEST PROCEDURES.

Perform the test as described in sections S6.1 and S6.2 or as described in section S6.3.

S6.1 ANALOG/DEVICE RETENTION WHEN INSTALLED IN THE EQUIPMENT MOUNTING DEVICE OR SYSTEM.

S6.1.1 Install the Equipment Mounting Device or System on the Test Surface and the Test Analog/Device into the Equipment Mounting Device or System as described in the manufacturer's instructions.

S6.1.2 Attach a cable or chain with a calibrated in-line gauge to the Test Analog/Device at a point representing the center of gravity of the Equipment.

S6.1.3 Apply the load to the Test Analog/Device to achieve the required force stated in S5.2. When the required force has been attained, hold that load for a minimum of 5 seconds.



STANDARDIZED TEST METHODS

- S6.1.4 Release applied load to achieve zero pounds.
- S6.1.5 Record the maximum load applied and any deformation or fracture of the Equipment Mounting Device or System.
- S6.2 EQUIPMENT MOUNTING DEVICE OR SYSTEM ATTACHMENT TO MODULE STRUCTURE.**
- S6.2.1 Install the Equipment Mounting Device or System as described in the manufacturer's instructions.
- S6.2.2 Attach a cable or chain with a calibrated in-line gauge to the Equipment Mounting Device or System at a point representing the composite center of gravity of the Equipment Mounting Device and the Equipment.
- S6.2.3 Apply the load to the Equipment Mounting Device or System to achieve the required force stated in S5.3. When the required force has been attained, hold that load for a minimum of 5 seconds.
- S6.2.4 Release applied load to achieve zero pounds.
- S6.2.5 Record the maximum load applied and any deformation or fracture of the Equipment Mounting Device or System.
- S6.3 TEST ANALOG/DEVICE AND EQUIPMENT MOUNTING DEVICE OR SYSTEM ATTACHMENT TO MODULE STRUCTURE.**
- S6.3.1 Install the Equipment Mounting Device or System and Test Analog/Device into the mount as described in the manufacturer's instructions.
- S6.3.2 Attach a cable or chain with a calibrated in-line gauge to the Test Analog/Device at a point representing the center of gravity of the Equipment.
- S6.3.3 Apply the load to the Test Analog/Device to achieve the required force stated in S5.3. When the required force has been attained, hold that load for a minimum of 5 seconds.
- S6.3.4 Release applied load to achieve zero pounds.
- S6.3.5 Record the maximum load applied and any deformation or fracture of the equipment mounting device or system.
- S7. TEST ACCEPTANCE CRITERIA.**
- S7.1 Deformation and displacement of the Equipment Mounting Device or System or the Test Analog/Device is acceptable.
- S7.2 Fracture is acceptable as long as load bearing components are not completely detached or fully severed.
- S7.3 The Equipment Mounting Device or System shall retain the Test Analog/Device for the duration of the test.
- S7.4 The Equipment Mounting Device or System shall remain attached to the Test Surface.



Annex to AMD Standardized Test Methods

AMD 005 Low Voltage Electrical System Test -- 2019

When performing the AMD 005 test in conjunction with the Federal Specification for the Star-of-Life Ambulance, KKK-A-1822, as the governing standard, the test shall be limited to the following minimum electrical loads consisting of the following electrical equipment and systems.

1. Engine/transmission control system.
2. Headlights (low beam).
3. All FMVSS 108 lights.
4. Windshield wipers (low speed).
5. Cab air conditioning (at coldest setting with highest blower speed).
6. Radio in receiving mode (or equal load, if not equipped).
7. Patient module dome lighting (in the high intensity setting).
8. Patient module air conditioning (at coldest setting with highest blower speed).
9. Emergency warning lighting system (in the daytime "primary" mode).
10. 20-amp medical load or equal.

AMD 012 Interior Climate Control Test – 2019

When performing the AMD 012 test in conjunction with the Federal Specification for the Star-of-Life Ambulance, KKK-A-1822, as the governing standard, the following figure may be used for guidance for the placement of thermocouples.

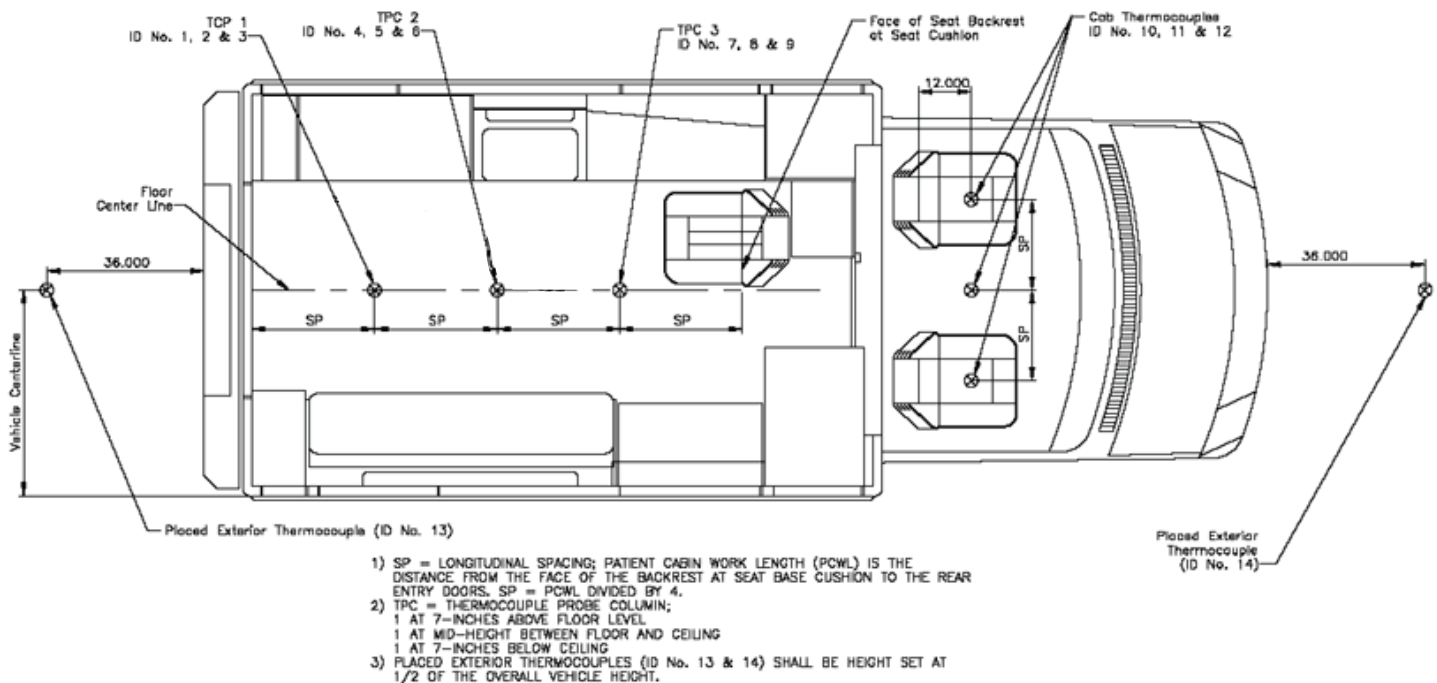



STANDARDIZED TEST METHODS

AMD 015 Ambulance Main Medical Gas System Test – 2019

When performing the AMD 015 test in conjunction with the Federal Specification for the Star-of-Life Ambulance, KKK-A-1822, as the governing standard, the following provides an example form of the label required to represent compliance of the main medical gas delivery system, as well as a figure depicting system pressure testing.

Example documentation

The integrity of this medical gas system was tested in accordance with AMD 015 and meets the requirements thereof.

Stage 1 Testing – Flow rate at each outlet:

Gas used for flow test (check one):

_____ Dry Nitrogen (110 LPM min. required)

_____ Breathing Air (110 LPM min. required)

_____ Oxygen (100 LPM min. required)

Note: For purposes of this test, 110 LPM of dry Nitrogen or Breathing Air is considered equivalent to 100 LPM of Oxygen.

Outlet # Flow Rate (LPM)

1. _____

2. _____

3. _____

4. _____

5. _____

6. _____

Stage 2 Testing – Pressure:

Initial Conditions for Stage 2 Testing:

Temperature: _____ °F

Pressure: _____ psi

Final Conditions for Stage 2 Testing:

Temperature: _____ °F

Pressure: _____ psi

Pressure Loss: _____ psi

Maximum Allowable Pressure Loss: 5psi

Signature of operator performing test: _____

Printed name of operator performing test: _____

Date of test: _____



STANDARDIZED TEST METHODS

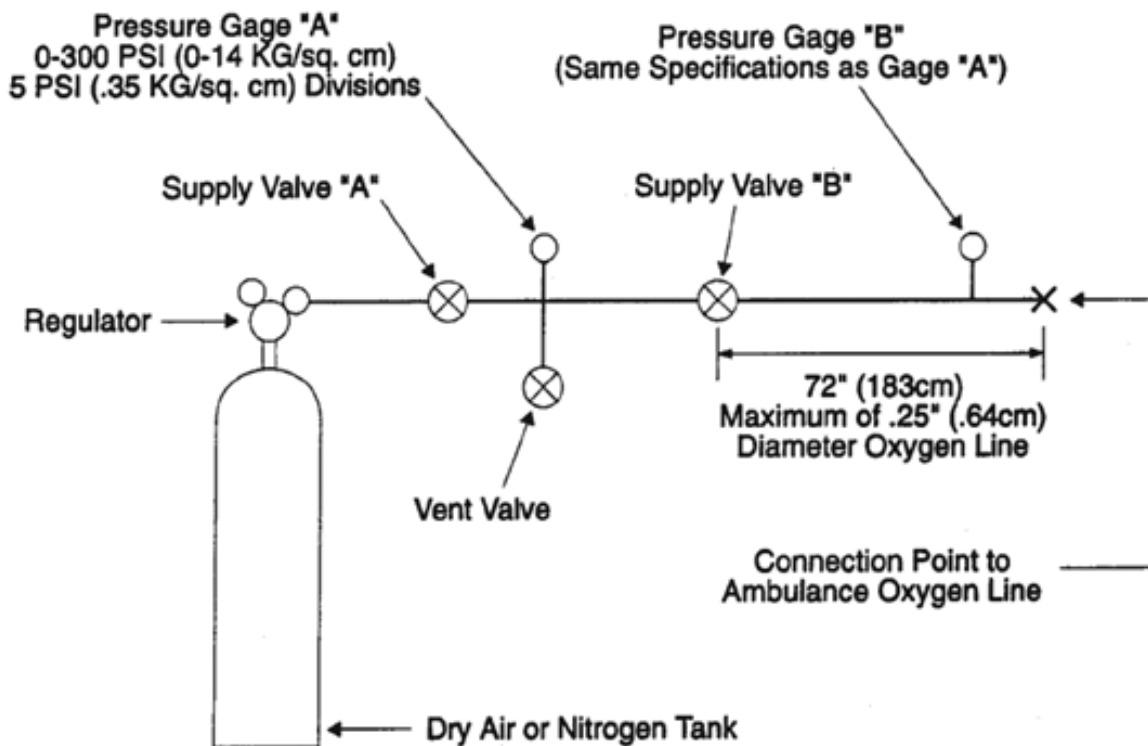

AMD 016 Patient Compartment Lighting Level Test – 2019

When performing the AMD016 test in conjunction with Federal Specification for the Star-of-Life Ambulance, KKK-A-1822, as the governing standard, the following provides a depiction of the locations for measuring floor or lighting intensity along the centerline of the patient compartment.

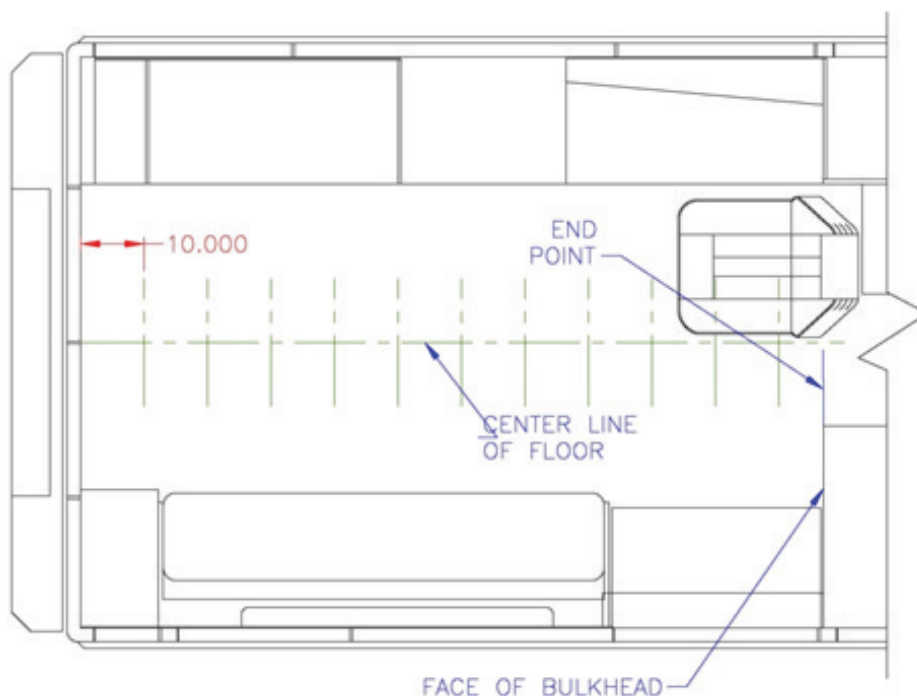



Administrative office

37400 Hills Tech Drive
Farmington Hills, MI 48331
800-441-6832
248-489-8590 FAX

Washington office

1701 Pennsylvania Ave. NW
Suite 200
Washington, DC 20006
202-552-1600

Ottawa office

1 Rideau St.
Suite 700
Ottawa, ON K1N 8S7 Canada
613-670-5877

ntea.com/amd

info@ntea.com